

PROJ. NO.: 22077

**STATE OF NORTH CAROLINA
DEPARTMENT OF TRANSPORTATION**

**PAVEMENT MARKING PLAN
ORANGE COUNTY**

**W. FRANKLIN STREET FROM MERRITT MILL ROAD
TO NC 86 (COLUMBIA STREET)**

<small>TIP NO.</small> 22077	<small>SHEET NO.</small> PMP - 1
<small>DocuSigned by:</small> APPROVED <i>William J. Hamilton</i> <small>A05600704848484</small>	
<small>DATE:</small> 04/25/2022	
	
<small>DOCUMENT NOT CONSIDERED FINAL UNLESS ALL SIGNATURES COMPLETED</small>	

ROADWAY STANDARD DRAWING

THE FOLLOWING ROADWAY STANDARDS AS APPEAR IN "ROADWAY STANDARD DRAWINGS" - PROJECT SERVICES UNIT - N.C. DEPARTMENT OF TRANSPORTATION - RALEIGH, N.C., DATED JANUARY 2018 ARE APPLICABLE TO THIS PROJECT AND BY REFERENCE HEREBY ARE CONSIDERED A PART OF THESE PLANS:

<u>STD. NO.</u>	<u>TITLE</u>
904.50	MOUNTING OF TYPE 'D', 'E' AND 'F' SIGNS ON 'U' CHANNEL POSTS
1205.01	PAVEMENT MARKINGS - LINE TYPES AND OFFSETS
1205.02	PAVEMENT MARKINGS - DIVIDED AND UNDIVIDED ROADWAYS
1205.04	PAVEMENT MARKINGS - INTERSECTIONS
1205.05	PAVEMENT MARKINGS - TURN LANES
1205.06	PAVEMENT MARKINGS - LANE DROPS
1205.07	PAVEMENT MARKINGS - PEDESTRIAN CROSSWALKS
1205.08	PAVEMENT MARKINGS - SYMBOLS AND WORD MESSAGES
1266.01	RAISED PAVEMENT MARKERS - TUBULAR MARKERS

PAVEMENT MARKINGS GENERAL NOTES

THE FOLLOWING GENERAL NOTES APPLY AT ALL TIMES FOR THE DURATION OF THE CONSTRUCTION PROJECT, EXCEPT WHEN OTHERWISE NOTED IN THE PLAN, OR DIRECTED BY THE ENGINEER.

- A) INSTALL PAVEMENT MARKINGS AND PAVEMENT MARKERS ON THE FINAL SURFACE AS FOLLOWS:

<u>ROAD NAME</u>	<u>MARKING</u>	<u>MARKER</u>
ALL ROADS	THERMOPLASTIC	NONE

- B) TIE PROPOSED PAVEMENT MARKING LINES TO EXISTING PAVEMENT MARKING LINES.
 C) REMOVE/REPLACE ANY CONFLICTING/DAMAGED PAVEMENT MARKINGS AND MARKERS.
 D) REFER TO APPROVED SIGNAL PLANS FOR STOP BAR LOCATIONS AT SIGNALIZED INTERSECTIONS.
 E) GREEN PAINT AND TUBULAR MARKERS ARE TO BE INSTALLED BY TOWN OF CHAPEL HILL.

PAVEMENT MARKING SCHEDULE

<u>SYMBOL</u>	<u>DESCRIPTION</u>
THERMOPLASTIC (4", 90 MILS)	
T1	WHITE EDGELINE
T2	WHITE SOLID LANE LINE
T4	3 FT. - 9 FT./SP WHITE MINISKIP
T5	2 FT. - 6 FT./SP WHITE MINISKIP
T10	YELLOW EDGELINE
T11	YELLOW SINGLE CENTER
T12	10 FT. YELLOW SKIP
T13	YELLOW DOUBLE CENTER
T14	2 FT. - 6 FT./SP YELLOW MINISKIP
THERMOPLASTIC (8", 90 MILS)	
T41	WHITE DIAGONAL
T42	YELLOW DIAGONAL
T43	WHITE SOLID LANE LINE
THERMOPLASTIC (12", 90 MILS)	
T53	WHITE SOLID LANE LINE
THERMOPLASTIC (24", 90 MILS)	
T61	WHITE STOPBAR
T62	WHITE CROSSWALK LINE
THERMOPLASTIC PAVEMENT MARKING SYMBOL	
T70	LEFT TURN ARROW
T71	RIGHT TURN ARROW
T72	STRAIGHT ARROW
T74	COMBO. RIGHT/STRAIGHT ARROW
T90	BICYCLE SYMBOL
T91	BICYCLE STRAIGHT ARROW
T93	BICYCLE CHAR.
T94	SHARROW
T100	ALPHANUMERIC CHAR.
T101	HANDICAP PARKING
T102	12" YIELD LINE TRIANGLE
T103	24" YIELD LINE TRIANGLE

SIGNING GENERAL NOTES

- . SIGNS FURNISHED BY TOWN.
- . IF REMOVAL OR RELOCATION OF SIGNS ON PRIVATE STREET (NON-STATE MAINTAINED) IS REQUIRED DUE TO CONSTRUCTION, THE CONTRACTOR SHALL INFORM THE ENGINEER. THE WORK WILL BE COMPLETED BY OTHERS.
- . WHEN NOT STATIONED OR DIMENSIONED ON PLANS, ALL 'E' AND 'F' SIGNS SHALL BE FIELD LOCATED BY THE ENGINEER.
- . THE BACKGROUND FOR TYPE E & F SIGNS SHALL BE TYPE C REFLECTIVE SHEETING.

INDEX

<u>SHEET NO.</u>	<u>DESCRIPTION</u>
PMP - 1	PAVEMENT MARKING PLAN COVER SHEET AND PAVEMENT MARKING SCHEDULE
PMP - 1A	PROJECT PAVEMENT MARKING DETAILS
PMP - 2 - 5	PAVEMENT MARKING DETAILS

PLANS PREPARED BY: Ramey Kemp Associates

W. JASON HAMILTON, P.E., PTOE PROJECT ENGINEER
JOSHUA A. WENDT, E.I. PROJECT DESIGNER



RAMEY KEMP ASSOCIATES
5508 Farrington Place
 Raleigh, North Carolina 27609
 Phone: 919-872-5115 NC License No. C-0910
 www.rameykemp.com

BUS ZONE PAVEMENT MARKING DETAIL

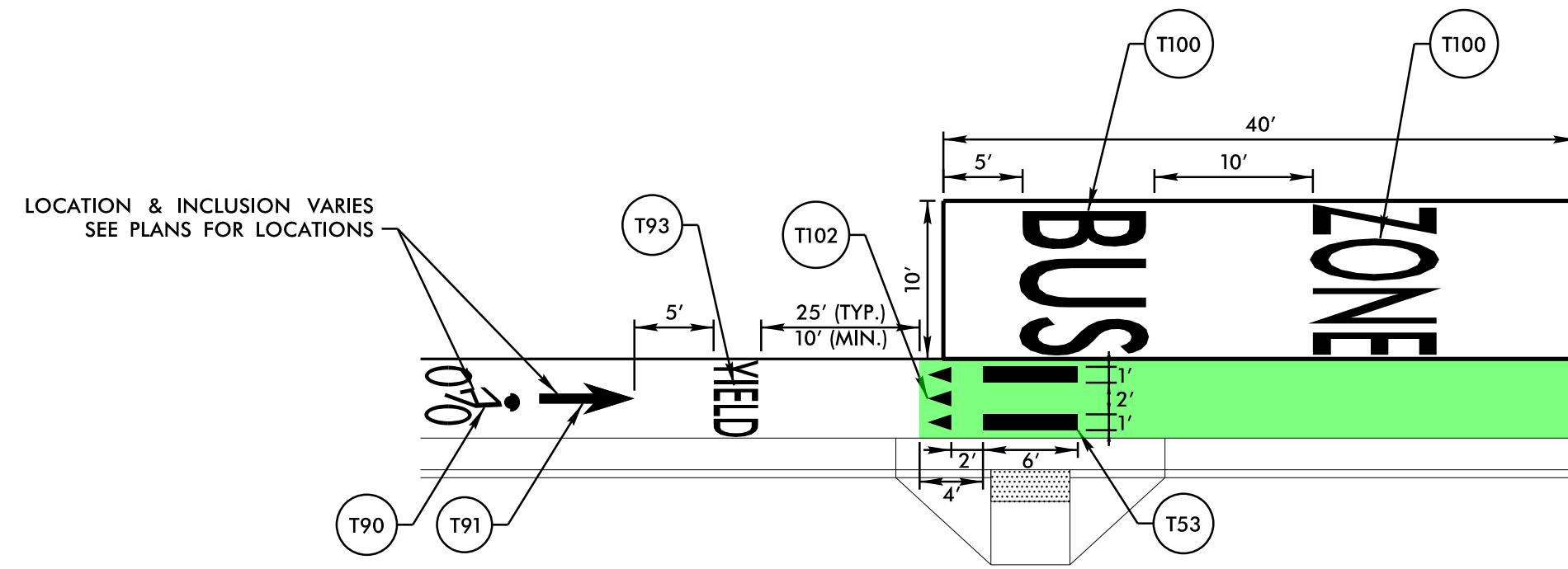

- NOTES:
1. USE AT LOCATIONS SPECIFIED ON PLANS.
 2. SCALE ALPHANUMERIC CHARACTERS TO FIT WITHIN DESIGNATED LANE LINES.
 3. VARIATIONS MAY BE REQUIRED BASED ON FIELD CONDITIONS. COORDINATE WITH ENGINEER AS NEEDED.
 4. GREEN PAINT TO BE INSTALLED BY TOWN OF CHAPEL HILL.

BIKE BOX PAVEMENT MARKING DETAIL

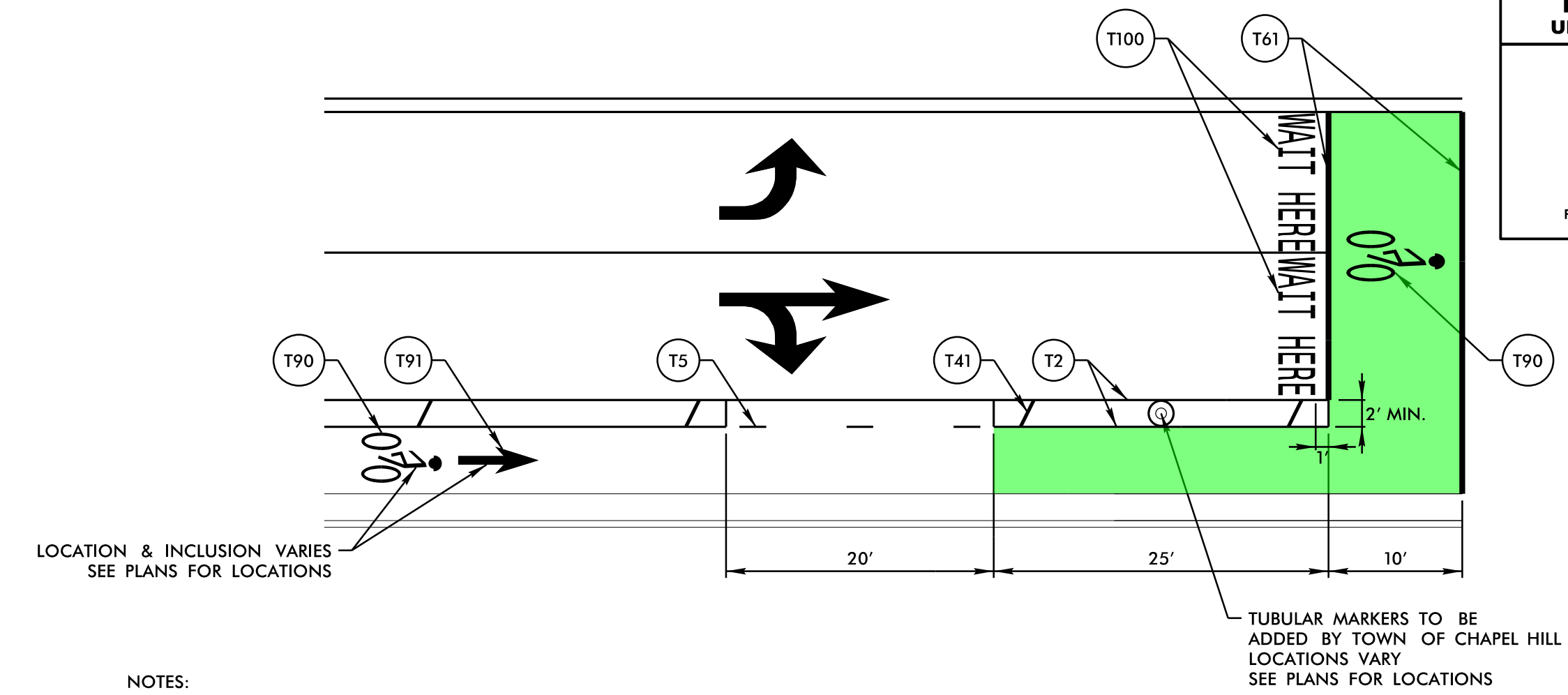

- NOTES:
1. USE AT LOCATIONS SPECIFIED ON PLANS.
 2. SCALE ALPHANUMERIC CHARACTERS TO FIT WITHIN DESIGNATED LANE LINES.
 3. VARIATIONS MAY BE REQUIRED BASED ON FIELD CONDITIONS. COORDINATE WITH ENGINEER AS NEEDED.
 4. GREEN PAINT TO BE INSTALLED BY TOWN OF CHAPEL HILL.

HANDICAP PARKING SPOT PAVEMENT MARKING DETAIL

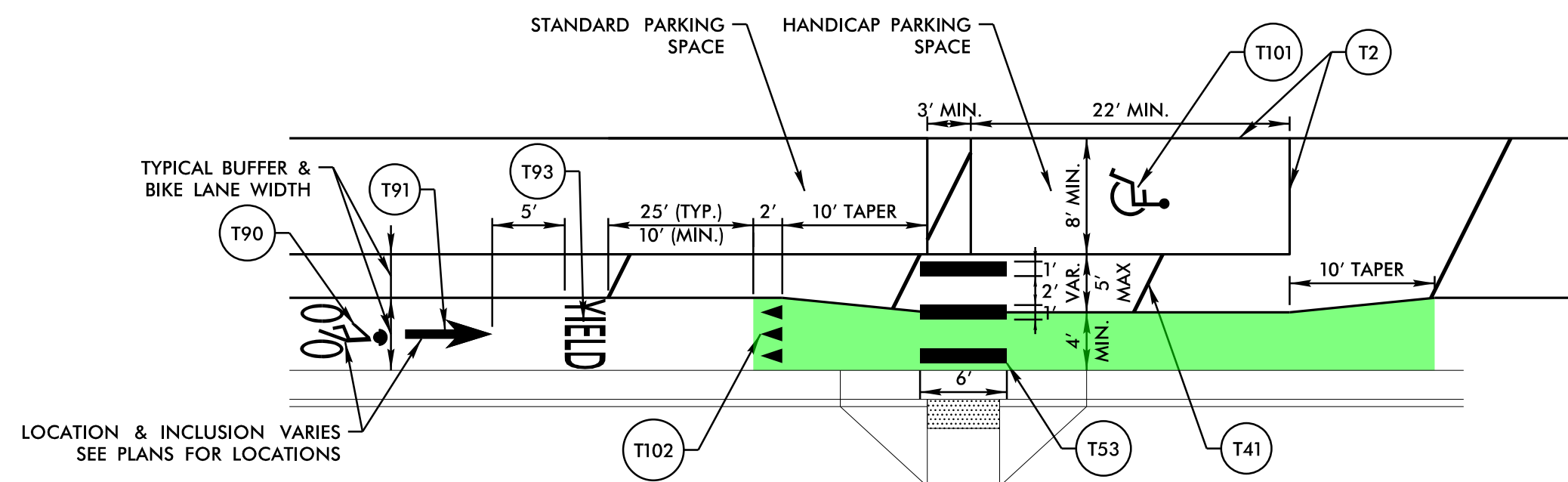

- NOTES:
1. USE AT LOCATIONS SPECIFIED ON PLANS.
 2. SCALE ALPHANUMERIC CHARACTERS TO FIT WITHIN DESIGNATED LANE LINES.
 3. NO OBSTRUCTION SHALL BE PLACED IN HANDICAP PARKING SPOT BUFFER.
 4. VARIATIONS MAY BE REQUIRED BASED ON FIELD CONDITIONS. COORDINATE WITH ENGINEER AS NEEDED.
 5. GREEN PAINT TO BE INSTALLED BY TOWN OF CHAPEL HILL.

TYPICAL DRIVEWAY PAVEMENT MARKING & MARKER LOCATION DETAIL

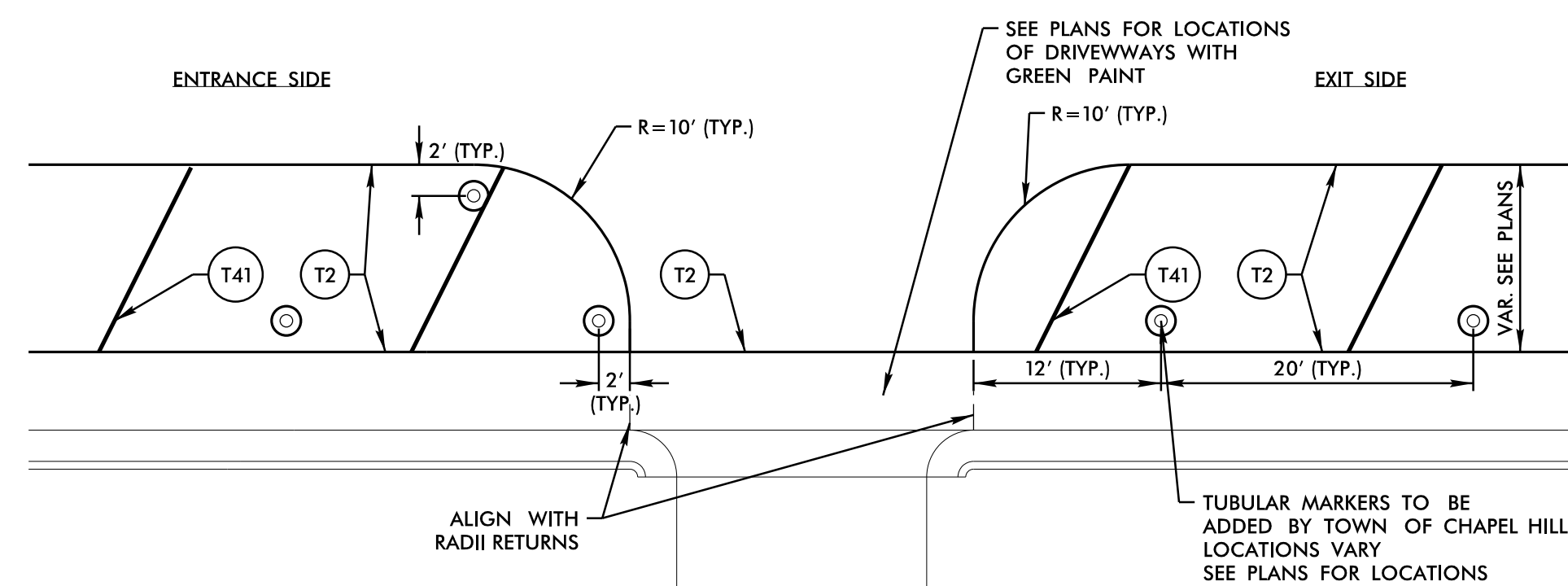

- NOTES:
1. VARIATIONS MAY BE REQUIRED BASED ON FIELD CONDITIONS. COORDINATE WITH ENGINEER AS NEEDED.
 2. GREEN PAINT TO BE INSTALLED BY TOWN OF CHAPEL HILL.
 3. TUBULAR MARKERS TO BE INSTALLED BY TOWN OF CHAPEL HILL.

LOADING ZONE PAVEMENT MARKING DETAIL

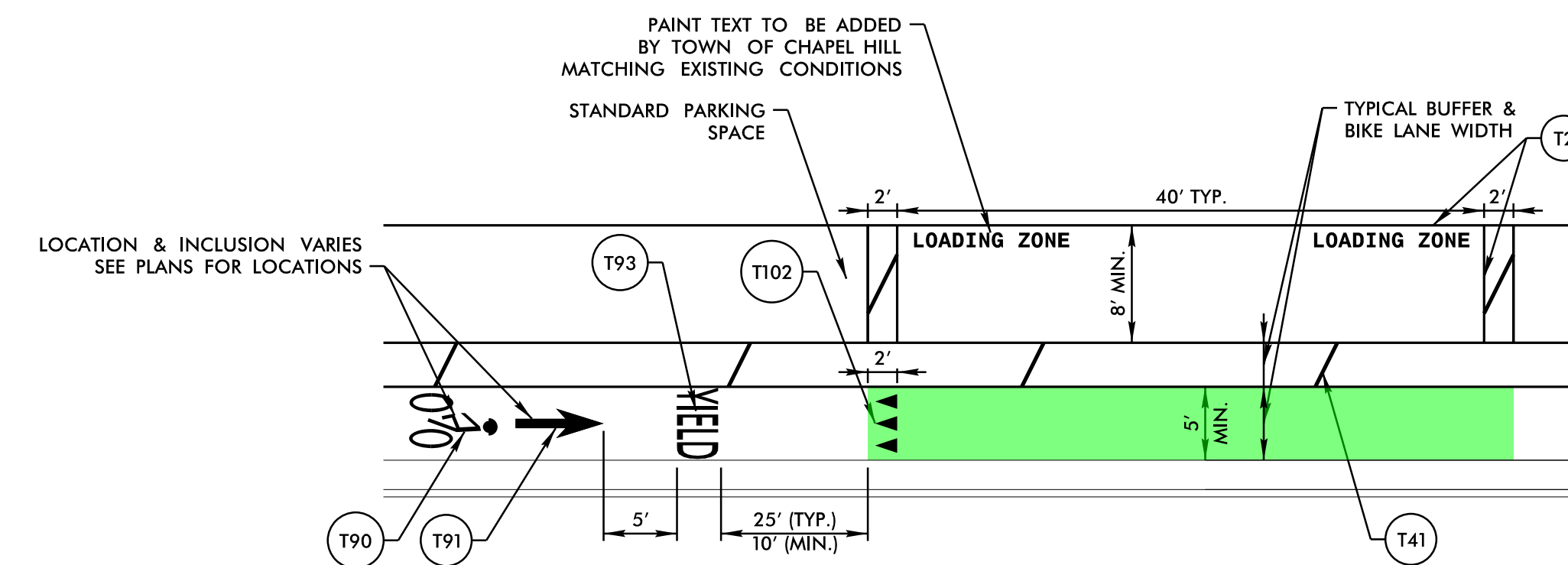

- NOTES:
1. USE AT LOCATIONS SPECIFIED ON PLANS.
 2. SCALE ALPHANUMERIC CHARACTERS TO FIT WITHIN DESIGNATED LANE LINES.
 3. NO OBSTRUCTIONS SHALL BE PLACED IN LOADING ZONE BUFFER.
 4. VARIATIONS MAY BE REQUIRED BASED ON FIELD CONDITIONS. COORDINATE WITH ENGINEER AS NEEDED.
 5. GREEN PAINT TO BE INSTALLED BY TOWN OF CHAPEL HILL.

PROJECT NO.	SHEET NO.
22077	PMP - 1A
APPROVED: <i>William J. Hamilton</i> ACCREDITED ASBESTOS ENGINEER	
DATE: 04/25/2022	
SEAL	
DOCUMENT NOT CONSIDERED FINAL UNLESS ALL SIGNATURES COMPLETED	
6808 Farrington Place Raleigh, North Carolina 27609 Phone: 919-872-5115 NC License No. C-0910 www.rameykemp.com	

- NOTES:
1. REFER TO PAVEMENT MARKING DETAILS ON PMP-1A FOR ADDITIONAL INFORMATION.
 2. DRAWINGS WERE PREPARED USING THE LATEST AVAILABLE AERIAL PHOTOGRAPHY AND FIELD MEASUREMENTS. NO SURVEY WAS PERFORMED IN PREPARATION OF THESE PLANS. COORDINATE WITH ENGINEER AS NEEDED.
 3. ALL CROSSWALKS ARE 10 FEET WIDE TO MATCH EXISTING UNLESS OTHERWISE NOTED.
 4. PROPOSED MARKED CROSSWALKS ARE TO BE LOCATED AT EXISTING LOCATIONS AND TO BE STRIPED BETWEEN EXISTING CURB RAMPS.
 5. BIKE LANE BUFFER WIDTH IS TO VARY TO PROVIDE A MINIMUM 5' WIDE BIKE LANE UNLESS OTHERWISE NOTED. AT LOCATIONS WITH PARKING THE MAXIMUM BUFFER WIDTH IS TO BE 4' WIDE UNLESS OTHERWISE NOTED.

SYMBOL LEGEND			
	T70	LEFT ARROW	ZONE T100 ALPHANUMERIC CHAR.
	T74	COMBO. RIGHT/STRAIGHT ARROW	WAIT HERE T100 ALPHANUMERIC CHAR.
	T90	BICYCLE SYMBOL	HANDICAP PARKING T101
	T91	BICYCLE STRAIGHT ARROW	12" YIELD LINE TRIANGLE (BIKE LANES) T102
	T93	BICYCLE CHAR., HEATED-IN-PLACE	TUBULAR MARKERS
	T100	ALPHANUMERIC CHAR.	

TYPICAL PARKING DIMENSIONS 8' X 22'

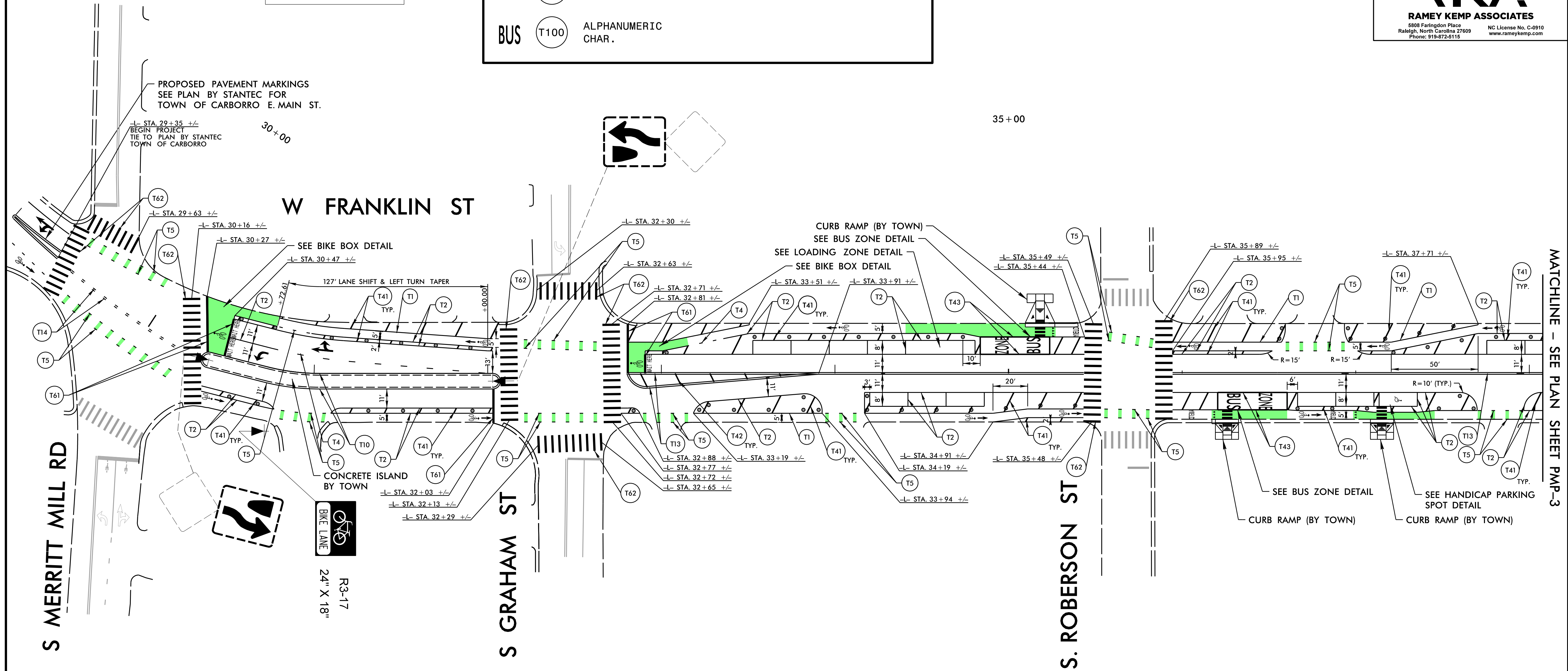

PROJECT NO.	SHEET NO.
22077	PMP-2
APPROVED:	
DATE: 04/25/2022	
SEAL	
DOCUMENT NOT CONSIDERED FINAL UNLESS ALL SIGNATURES COMPLETED	
6808 Farrington Place Raleigh, North Carolina 27609 Phone: 919-872-5115	

PAVEMENT MARKING DETAIL

MATCHLINE - SEE PLAN SHEET PMP-3

- NOTES:
1. REFER TO PAVEMENT MARKING DETAILS ON PMP-1A FOR ADDITIONAL INFORMATION.
 2. DRAWINGS WERE PREPARED USING THE LATEST AVAILABLE AERIAL PHOTOGRAPHY AND FIELD MEASUREMENTS. NO SURVEY WAS PERFORMED IN PREPARATION OF THESE PLANS. COORDINATE WITH ENGINEER AS NEEDED.
 3. ALL CROSSWALKS ARE 10 FEET WIDE TO MATCH EXISTING UNLESS OTHERWISE NOTED.
 4. PROPOSED MARKED CROSSWALKS ARE TO BE LOCATED AT EXISTING LOCATIONS AND TO BE STRIPED BETWEEN EXISTING CURB RAMP.
 5. BIKE LANE BUFFER WIDTH IS TO VARY TO PROVIDE A MINIMUM 5' WIDE BIKE LANE UNLESS OTHERWISE NOTED. AT LOCATIONS WITH PARKING THE MAXIMUM BUFFER WIDTH IS TO BE 4' WIDE UNLESS OTHERWISE NOTED.

SYMBOL LEGEND			
	T90	BICYCLE SYMBOL	ZONE T100 ALPHANUMERIC CHAR.
	T91	BICYCLE STRAIGHT ARROW	ZONE T101 HANDICAP PARKING
	T93	BICYCLE CHAR., HEATED-IN-PLACE	ZONE T102 12" YIELD LINE TRIANGLE (BIKE LANES)
	T100	ALPHANUMERIC CHAR.	○ ○ ○ ○ TUBULAR MARKERS

PROJECT NO.	SHEET NO.
22077	PMP-3
APPROVED:	
DATE: 04/25/2022	
SEAL	
DOCUMENT NOT CONSIDERED FINAL UNLESS ALL SIGNATURES COMPLETED	
6808 Farrington Place Raleigh, North Carolina 27609 Phone: 919-872-5115	

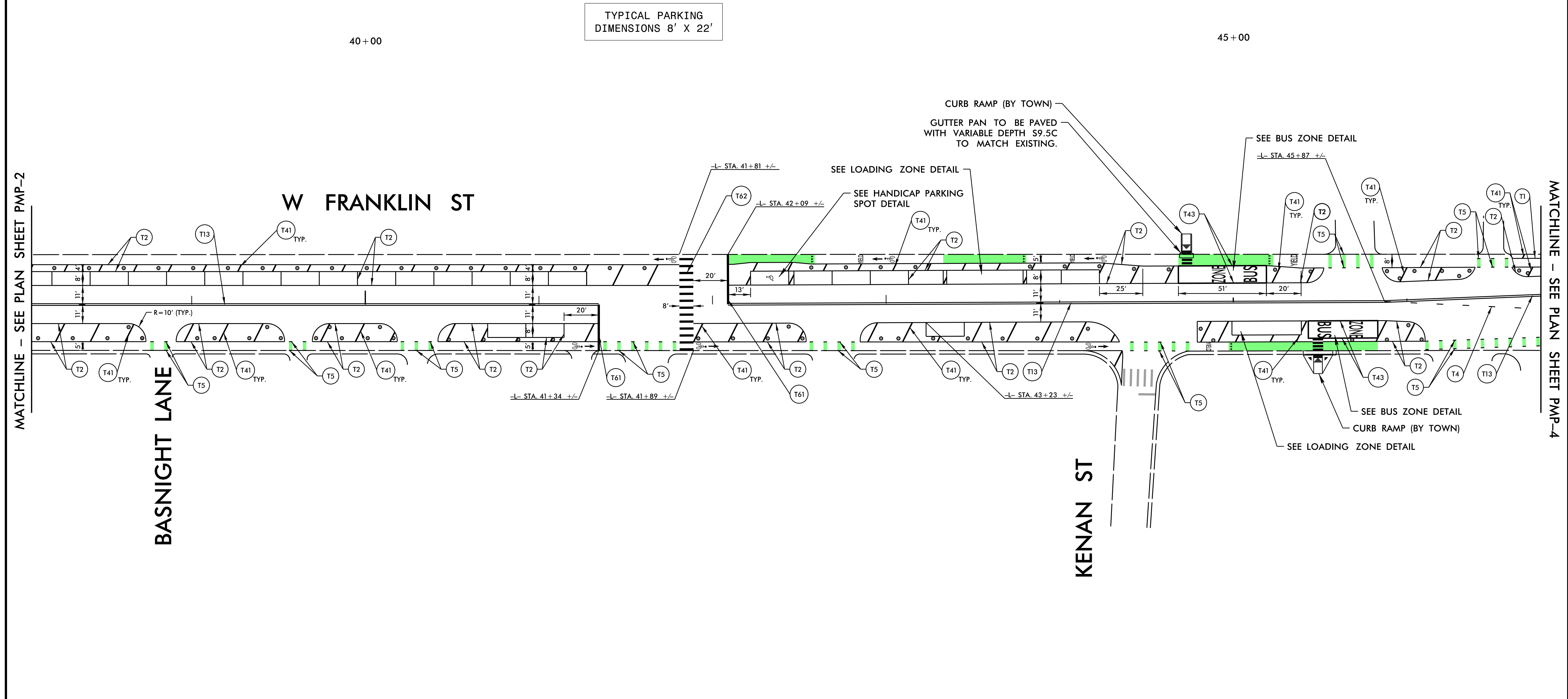

PAVEMENT MARKING DETAIL

NOTES:

1. REFER TO PAVEMENT MARKING DETAILS ON PMP-1A FOR ADDITIONAL INFORMATION.
2. DRAWINGS WERE PREPARED USING THE LATEST AVAILABLE AERIAL PHOTOGRAPHY AND FIELD MEASUREMENTS. NO SURVEY WAS PERFORMED IN PREPARATION OF THESE PLANS. COORDINATE WITH ENGINEER AS NEEDED.
3. ALL CROSSWALKS ARE 10 FEET WIDE TO MATCH EXISTING UNLESS OTHERWISE NOTED.
4. PROPOSED MARKED CROSSWALKS ARE TO BE LOCATED AT EXISTING LOCATIONS AND TO BE STRIPED BETWEEN EXISTING CURB RAMPS.
5. BIKE LANE BUFFER WIDTH IS TO VARY TO PROVIDE A MINIMUM 5' WIDE BIKE LANE UNLESS OTHERWISE NOTED. AT LOCATIONS WITH PARKING THE MAXIMUM BUFFER WIDTH IS TO BE 4' WIDE UNLESS OTHERWISE NOTED.

SYMBOL LEGEND	
	T70 LEFT ARROW
	T74 COMBO. RIGHT/STRAIGHT ARROW
	T90 BICYCLE SYMBOL
	T91 BICYCLE STRAIGHT ARROW
WAIT HERE	T100 ALPHANUMERIC CHAR.
	T101 HANDICAP PARKING
	TUBULAR MARKERS

50+00

PROJECT NO.	SHEET NO.
22077	PMP-4
APPROVED: <i>William J. Hamilton</i>	
DATE: 04/25/2022	
SEAL	
DOCUMENT NOT CONSIDERED FINAL UNLESS ALL SIGNATURES COMPLETED	
6808 Farrington Place Raleigh, North Carolina 27609 Phone: 919-872-5115	



55+00

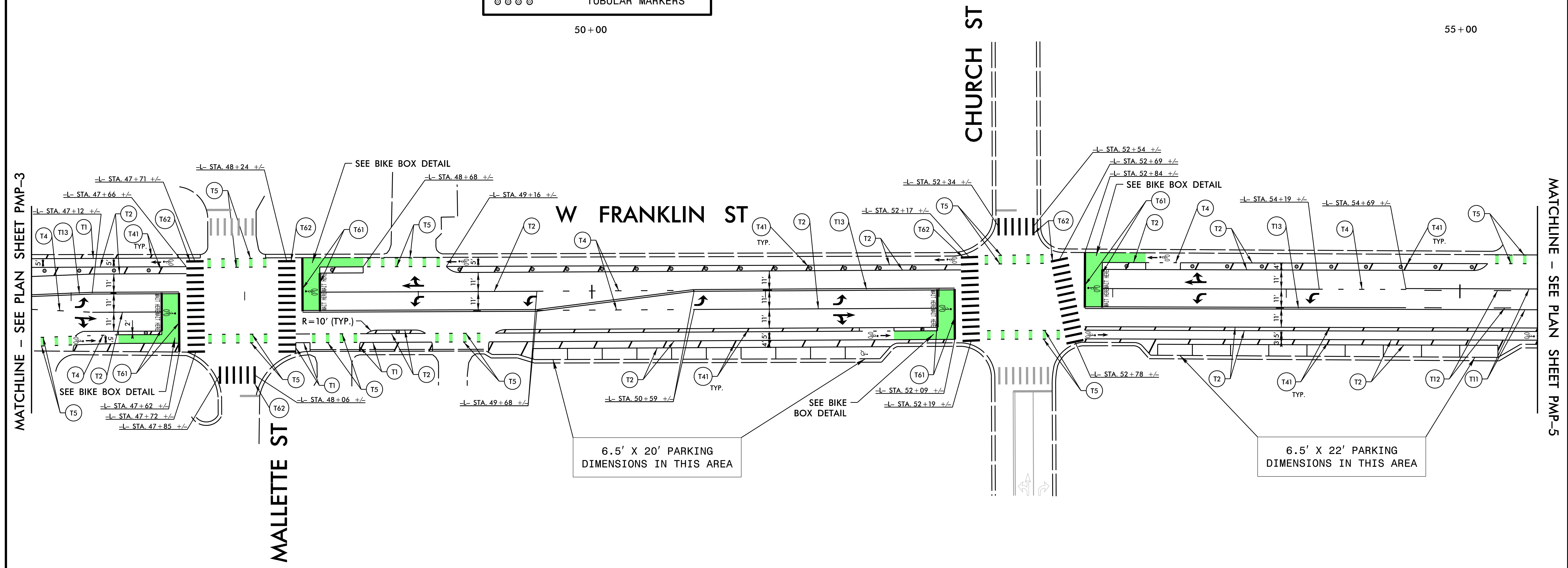

PAVEMENT MARKING DETAIL

NOTES:

1. REFER TO PAVEMENT MARKING DETAILS ON PMP-1A FOR ADDITIONAL INFORMATION.
2. DRAWINGS WERE PREPARED USING THE LATEST AVAILABLE AERIAL PHOTOGRAPHY AND FIELD MEASUREMENTS. NO SURVEY WAS PERFORMED IN PREPARATION OF THESE PLANS. COORDINATE WITH ENGINEER AS NEEDED.
3. ALL CROSSWALKS ARE 10 FEET WIDE TO MATCH EXISTING UNLESS OTHERWISE NOTED.
4. PROPOSED MARKED CROSSWALKS ARE TO BE LOCATED AT EXISTING LOCATIONS AND TO BE STRIPED BETWEEN EXISTING CURB RAMP.
5. BIKE LANE BUFFER WIDTH IS TO VARY TO PROVIDE A MINIMUM 5' WIDE BIKE LANE UNLESS OTHERWISE NOTED. AT LOCATIONS WITH PARKING THE MAXIMUM BUFFER WIDTH IS TO BE 4' WIDE UNLESS OTHERWISE NOTED.

SYMBOL LEGEND					
	T70	LEFT ARROW		T94	SHARROW
	T71	RIGHT ARROW		T100	ALPHANUMERIC CHAR.
	T72	STRAIGHT ARROW		T100	ALPHANUMERIC CHAR.
	T74	COMBO. RIGHT/ STRAIGHT ARROW		T102	12" YIELD LINE TRIANGLE (BIKE LANES)
	T90	BICYCLE SYMBOL		T103	24" YIELD LINE TRIANGLE
	T91	BICYCLE STRAIGHT ARROW			TUBULAR MARKERS
	T93	BICYCLE CHAR., HEATED-IN-PLACE			

**THRU TRAFFIC
MERGE
LEFT**

W4-7L
36" X 36"

W4-7L SIGN WILL BE INSTALLED BY TOWN OF CHAPEL HILL IN CONSPICUOUS LOCATION APPROXIMATELY 500 FEET TO THE EAST OF THE INTERSECTION, NEAR HENDERSON STREET. W4=7L SIGN SHALL HAVE YELLOW RETROREFLECTIVE SHEETING PER DIVISION REQUEST.



PROJECT NO.	SHEET NO.
22077	PMP-5
APPROVED: <i>William J. Hamilton</i> A05500704648484	
DATE: 04/25/2022	
SEAL	
DOCUMENT NOT CONSIDERED FINAL UNLESS ALL SIGNATURES COMPLETED	
<small>6808 Farrington Place Raleigh, North Carolina 27609 Phone: 919-872-5115</small>	

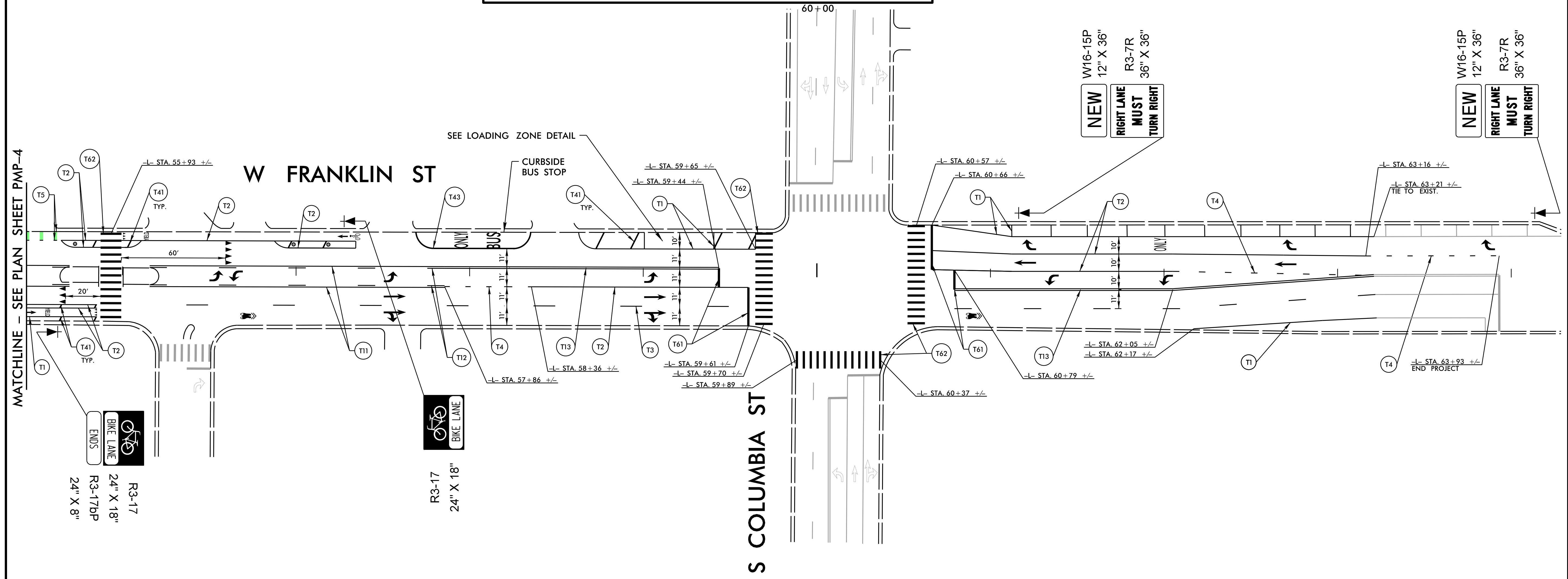

PAVEMENT MARKING DETAIL