

\\chfs\Engineering\Design Manual\Standard Details for 2023 Revision\CAD\CAD details\EC-102.dwg

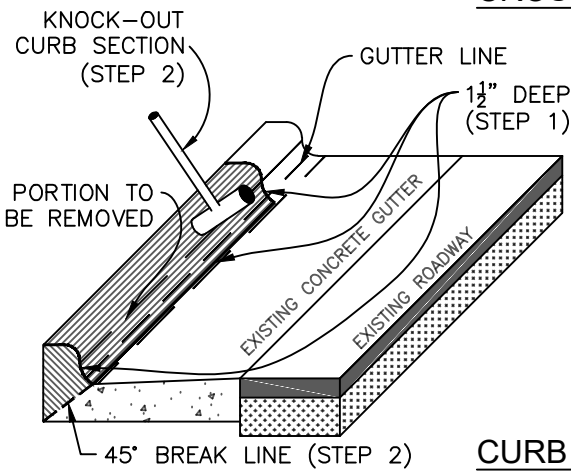
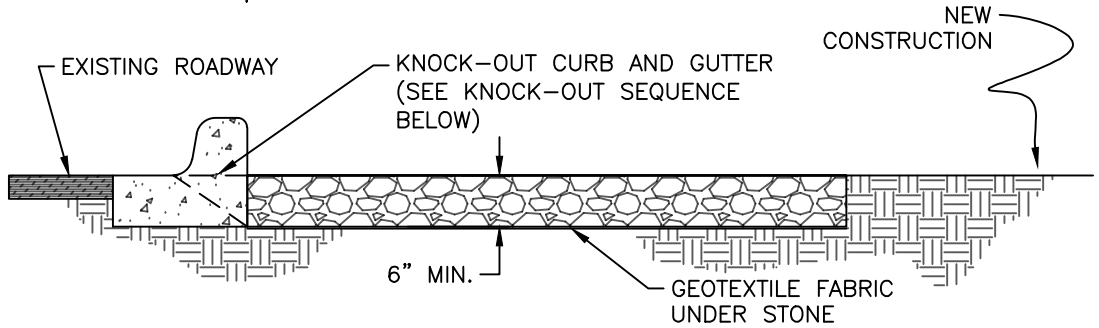
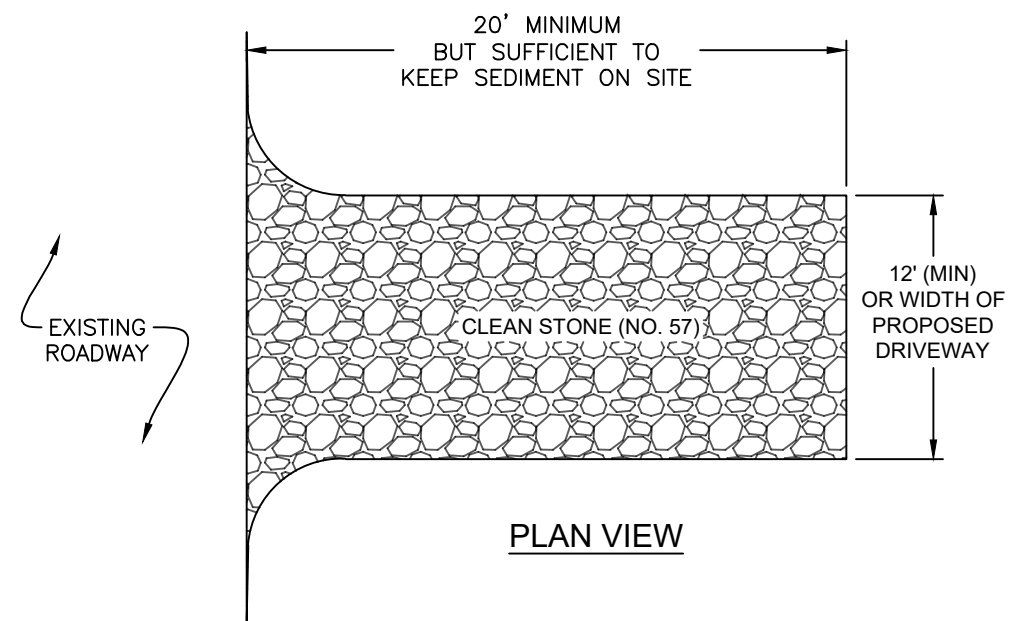

CONCRETE CURB KNOCK-OUT SEQUENCE:

- 1: A 1 1/2" DEEP CUT SHALL BE MADE PERPENDICULAR TO BACK OF CURB AND THEN PARALLEL WITH GUTTER LINE
- 2: KNOCK-OUT SECTION OF CURB TO BE REMOVED, ACHIEVING A 45° BREAK ANGLE, AND CLEAN EDGES ON CURB TO REMAIN

" NOT TO SCALE "

- CONSTRUCTION NOTES:**
1. CLEAR THE ENTRANCE AND EXIT AREA OF ALL VEGETATION, ROOTS, AND OTHER OBJECTIONABLE MATERIAL AND PROPERLY GRADE IT.
 2. PLACE THE GRAVEL TO THE SPECIFIC GRADE AND DIMENSIONS SHOWN ON THE PLANS, AND SMOOTH IT.
 3. PROVIDE DRAINAGE TO CARRY WATER TO A SEDIMENT TRAP OR OTHER SUITABLE OUTLET.
 4. USE GEOTEXTILE FABRICS IN ORDER TO IMPROVE STABILITY OF THE FOUNDATION IN LOCATIONS SUBJECT TO SEEPAGE OR HIGH WATER TABLE.
 5. IF CONSTRUCTION ON THE SITE IS OF SUCH NATURE THAT SUFFICIENT MUD IS NOT REMOVED FROM THE VEHICLE TRAVELING OVER THE STONE, THEN THE TIRES OF VEHICLES LEAVING THE SITE MUST BE WASHED BEFORE ENTERING THE PUBLIC ROAD.

- MAINTENANCE NOTES:**
1. INSPECT ALL MEASURES AT LEAST WEEKLY AND AFTER EACH RAINFALL OF 1.0 INCH OR GREATER. MAKE ANY REQUIRED REPAIRS IMMEDIATELY.
 2. MAINTAIN THE GRAVEL PAD IN A CONDITION TO PREVENT MUD OR SEDIMENT FROM LEAVING THE CONSTRUCTION SITE. THIS MAY REQUIRE PERIODIC TOPDRESSING WITH CLEAN STONE.
 3. SEDIMENT ON ROADWAYS IS TO BE REMOVED IMMEDIATELY BY BROOM AND SHOVEL, EITHER BY MANUAL OR MECHANICAL MEANS, AND NOT TO BE WASHED OFF WHERE IT HAS THE POTENTIAL TO ENTER A STREAM, DRAINAGE WAY OR STORM DRAIN SYSTEM.

NOTE:
THIS ENTRANCE APPLIES ONLY TO ENTRANCES OF INDIVIDUAL SINGLE FAMILY RESIDENTIAL UNITS. ALL OTHER PROJECTS SHALL UTILIZE A COMMERCIAL CONSTRUCTION ENTRANCE (CHAPEL HILL DETAIL EC-1.01)



TOWN OF CHAPEL HILL
STANDARD DETAIL

REVISIONS
05/2024

**RESIDENTIAL
CONSTRUCTION
ENTRANCE**

DATE: 02/2017

EC-1.02