

NCDOT STREETS

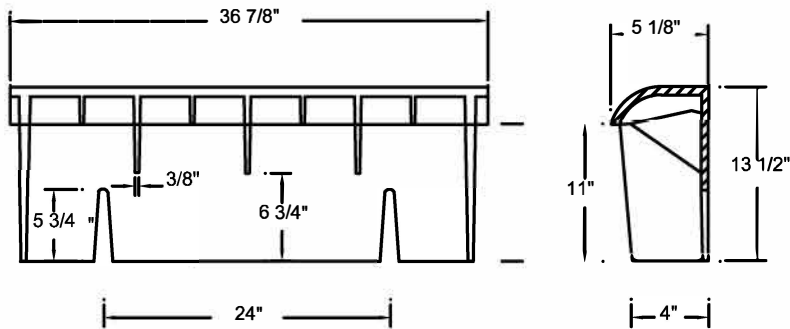
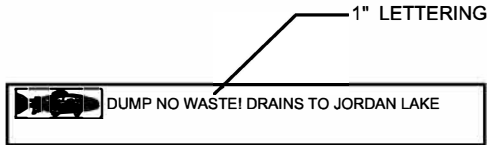

STORMDRAIN CURB INLET HOOD FOR INSTALLATION ON STATE STREETS AND INSTALLATIONS UNDER THE JURISDICTION OF THE NORTH CAROLINA DEPARTMENT OF TRANSPORTATION AND SHALL COMPLY WITH ASTM A48 CL35. IT SHALL BE A HEAVY DUTY TRAFFIC BEARING GRATE WITH AN APPROXIMATE TOTAL WEIGHT OF 575 LBS. (INCLUDES WEIGHT OF GRATE, FRAME & HOOD).

NOTES:

1. ALL STORMDRAIN INLET HOODS AND COVERS INSTALLED OR REPLACED WITHIN THE CHAPEL HILL PLANNING JURISDICTION AFTER JULY 31, 2000 SHALL BE PRE-CAST WITH THE MESSAGE: "DUMP NO WASTE! DRAINS TO JORDAN LAKE" (INCLUDING THE CAST IMAGE OF A FISH).
2. PRE-CAST HOODS AND COVERS SHALL BE DESIGNED IN ACCORDANCE WITH THE ABOVE MATERIAL SPECIFICATIONS AND MUST COMPLY WITH APPLICABLE STATE AND TOWN REQUIREMENTS FOR MATERIALS AND INSTALLATION.
3. CASTING MUST BE MANUFACTURED IN THE UNITED STATES. MANUFACTURER MUST BE APPROVED BY THE TOWN OF CHAPEL HILL.

" NOT TO SCALE "

T.O.C.H. STREETS

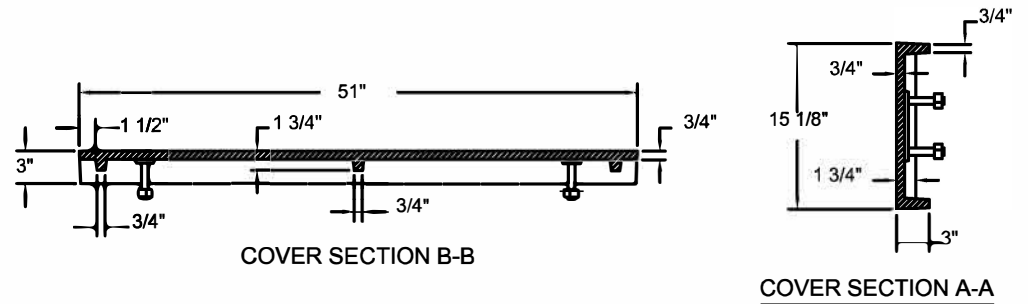
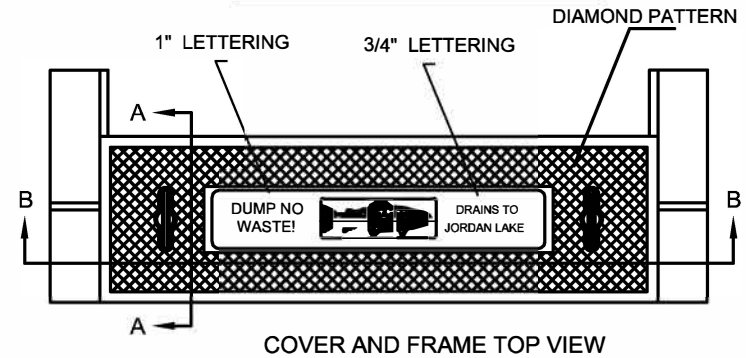

STORMDRAIN CURB INLET COVER FOR INSTALLATION ON TOWN STREETS AND INSTALLATIONS UNDER THE JURISDICTION OF THE TOWN OF CHAPEL HILL SHALL COMPLY WITH ASTM A48 CL35. IT SHALL BE A LIGHT DUTY COVER HAVING AN APPROXIMATE TOTAL WEIGHT OF 307 LBS. (INCLUDES WEIGHT OF COVER AND TWO LEGS).



DATE: 02/2017

TOWN OF CHAPEL HILL
STANDARD DETAIL

REVISIONS

CURB INLET
HOOD & COVER

SW-2.04