

NOTES:

1. PIPE TO BE RCP AND SIZED TO CARRY THE DESIGN FLOW OF THE DITCH FOR A 10-YEAR, 24-HOUR STORM EVENT; THE MINIMUM ACCEPTABLE PIPE SIZE IS 15" IF THE DESIGN FLOW WOULD REQUIRE A SMALLER PIPE.
2. 6" MINIMUM COVER OVER PIPE MEASURED FROM TOP OF PAVEMENT.
3. STEEPER SLOPES CAN BE ALLOWED WHERE SPECIAL STABILIZATION IS PROVIDED IN ACCORDANCE WITH EROSION AND SEDIMENTATION CONTROL ORDINANCE.
4. USE 5' VERTICAL CURVE FOR TRANSITION.
5. SOD OR SEED FULL EXTENT OF R/W LIMITS ALONG FRONTAGE FINISHED GRADE OF SOD TO BE 1" BELOW EDGE OF ROADWAY.

WITH UNPAVED ROADSIDE DITCH

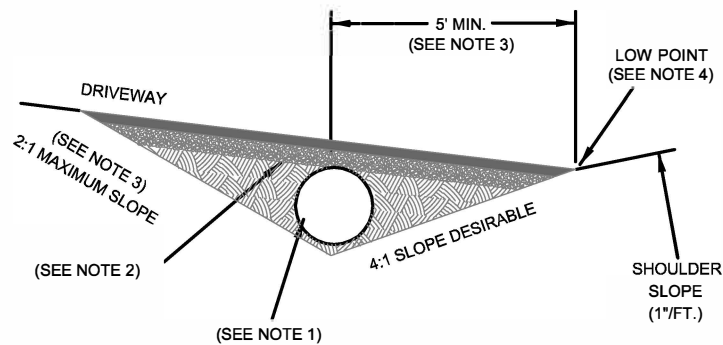

" NOT TO SCALE "



DATE: 02/2017

**TOWN OF CHAPEL HILL
STANDARD DETAIL**

REVISIONS

**RESIDENTIAL
DRIVEWAY APRON
NON CURB &
GUTTER STREETS**

T-10.02